

Vineyard/orchard/market gardening soil preparation



POWER TILLERS EL 43-53-62-82-92

POWER HARROWS HRB 122-152-182-202

www.kuhn.com



be strong, be **KUHN**



EL

43

53

62

82

92

HRB

122

152

182

202

SPECIALISTS THROUGH THEIR SIZE, SHAPE AND SPECIFICATIONS

DEMANDING HIGH QUALITY WORK IN ALL CONDITIONS

Whatever you need the machine for, the work should be of high quality. KUHN's driven soil preparation tools ensure this, while being extremely versatile in their use.

INVESTING IN ROBUST MACHINES

KUHN equipment is renowned for its robustness and long service life. Benefit from the safety, reliability and longevity of our machines.

MULTIPURPOSE TOOLS FOR MULTIPURPOSE USE

KUHN vineyard and orchard power tillers have a very compact design to work in narrow row spacing. These power tillers excel in quality seedbed preparation in all conditions.

Soil preparation tools for vineyards and orchards in brief:

	Working widths (m)	Minimum power requirement (kW/hp)
EL 43	1.07 - 1.89	10/14 - 15/20
EL 53	0.97 - 1.88	13/18 - 24/32
EL 62	1.20 - 2.10	17/23 - 31/42
EL 82	1.30 - 2.05	24/33 - 38/51
EL 92	1.80 - 2.30	33/45 - 43/58
HRB 122	1.20	18/25
HRB 152	1.50	22/30
HRB 182	1.80	26/35
HRB 202	2.10	30/40



MULTI-PURPOSE TOOLS FOR MULTI-PURPOSE USE

KUHN's power tillers and power harrows perform in different fields. You can use these machines for mechanical weed control between the rows, incorporation of plant matter into the soil and soil improvement work (loosening, crumbling). To adapt to these different uses, it is highly important that the working intensity can be adapted equally.



STILL USABLE WHERE OTHER TOOLS QUIT

Power tillers and harrows are often called the „fire brigade“ of vine and fruit growers, because of their unrivalled versatility, also in most arduous conditions. They are of such robustness that even difficult soils or stones will not stop them.

IMPROVE YOUR SOIL

KUHN power tillers and harrows are designed for shallow soil loosening and breaking up of clods. Thus, an improved uptake of surface water is achieved. For impeccable results and to avoid erosion, it is important to choose the right moment for this operation and an adapted work intensity.





SHRED AND INCORPORATE PLANT DEBRIS

Shredding annual shoots, incorporating mulch and cover plants into the soil or ploughing up a permanent plant cover, established over the winter: Especially the C-blades of KUHN power tillers provide exceptional shredding of plant matter before working it into the soil.



NO CHANCE FOR WEEDS

During the vegetation period weeds compete for nutrients and water with vines and fruit trees. Spring or summer tillage with power tillers and harrows constitutes an environmentally friendly alternative to chemical control. Soil organisms are thus treated carefully, while the weeds are permanently weakened.



ROBUST AND RELIABLE WORK QUALITY AND VERSATILITY

A robust tool is what farmers expect when buying a power tiller. KUHN power tillers meet these needs, when mastering difficult soils and the presence of stones without impact on the longevity of the machine.

SAFE AND RELIABLE HEADSTOCK

The coupling yokes and headstocks of the EL tillers have been carefully designed. Sturdy and reliable, these components meet the demands of the user.



VERY RIGID: LARGE SECTION FRAME

The EL 62, 82 and 92 are characterized by a one-piece large box-type frame providing high rigidity and resistance to fatigue and shocks. The front tube integrated in the casing increases the unit's robustness and enables to fit further equipment.

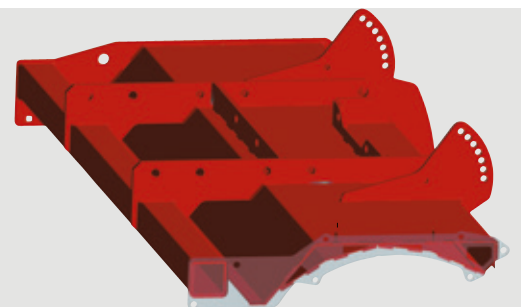

ROTOR DRIVE OPTIMUM OPERATING PERFORMANCE

Reliable, safe with little maintenance required: What else would you expect from the rotor drive of your power tiller? Right: a robust design.



EL 43/53: LONG SERVICE LIFE

The rotor is driven by tempered steel sprockets, located in a side chain case with thick walls. The oversized chain with automatic tension adjustment is much more resistant to fatigue than competitive models (EL 53). The drive chain is lubricated in an oil bath.

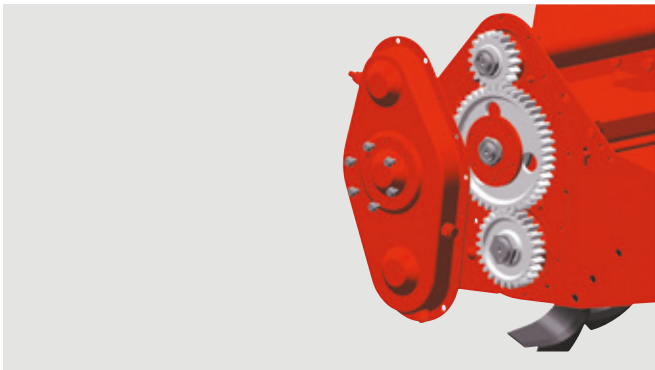

EL 62/82/92: HIGH CAPACITY DRIVE

On the larger EL models the rotor is driven by case hardened forged steel gearwheels, which are mounted on tapered roller or roller bearings for maximum capacity. They run in an oilbath.

Heavy-duty sealing: The lower gearcase is fitted with a metallic face seal, which means highest possible resistance to leaking and contamination in abrasive soil conditions.

CENTRAL GEARBOX RUGGED AND PERFORMING

EL 43/53: REDUCED ANGLES FOR INCREASED SERVICE LIFE

The central cast iron gearbox of the smaller models is mounted directly on the tiller frame with hardened forged steel gearwheels that run in an oil bath. It can be offset together with the 3-point frame to avoid an unfavourable angle on the drive. This allows to work easily under trees and realize greenhouse borders. The drive is protected as standard by a friction slip clutch.

EL 62/82/92: ALL BASICS INCLUDED, BUT EVEN MORE VERSATILE

Also on the larger models, the central gearbox is cast iron and set far back for reduced PTO angles. A friction slip clutch is standard for protection of the drive train. What is new here is the Duplex gearbox with two standard speeds on the EL 92. Two additional speeds are available as optional equipment, offering the adaptation to various work conditions. The EL 62 Duplex gearbox offers two speeds by inverting the gearwheels.

Central gearbox:
U-joints always in line with the tractor

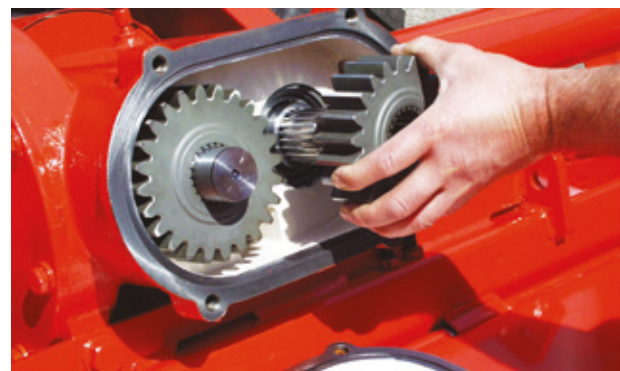

Duplex gearbox on EL 92

PROVIDING HIGH WORK QUALITY AND VERSATILITY

KUHN power tillers for vineyards and orchards are versatile tools, answering the various needs and requirements of vinegrowers, market gardeners, horticulturalists etc.; with their sophisticated features, they provide an exceptional work quality and efficiency in a wide range of conditions.



PROGRESSIVE LATERAL OFFSET

Offset hitch capability normally allows a tiller that is narrower than the tractor to erase the tractor wheel track on its right side. Offsetting the hitch is easily accomplished by sliding the three yokes of the tiller frame. The gearbox moves with the hitch and keeps in line with the power take-off. The machine can be adapted to match the various situations and ensure perfect stability.

C-BLADES FOR OPTIMUM TILLAGE

The special curved design of the KUHN tiller blades has been optimized, tested and provides:

- chopping and mixing of plant residues,
- aggressive entry into hard soil while requiring less horsepower,
- increased crumbling of soil clods.

The EL 43 is fitted with four blades per flange as standard (six as option), while all other models possess six of them for even more efficient crumbling. For shallow work, L-blades can be fitted on EL 53-92.

REAR HOOD A MATCH FOR ALL CONDITIONS

The rear hood of EL tillers is ideally shaped for a uniform soil flow and adaptable to various conditions: shallow or deep tillage, dry or wet soil, different quantities of plant residues. Now it is your turn to adapt the hood to your needs.

Series	Model	Offset
EL 43	105/130/150	22/32/42
	190	fixed
EL 53	100/130/155	155/300/300
	190	fixed
EL 62	120	170
	130/155/165/180	200
	210	fixed
EL 82	130/155/180	220
	205	fixed
EL 92	180	110
	205/230	fixed

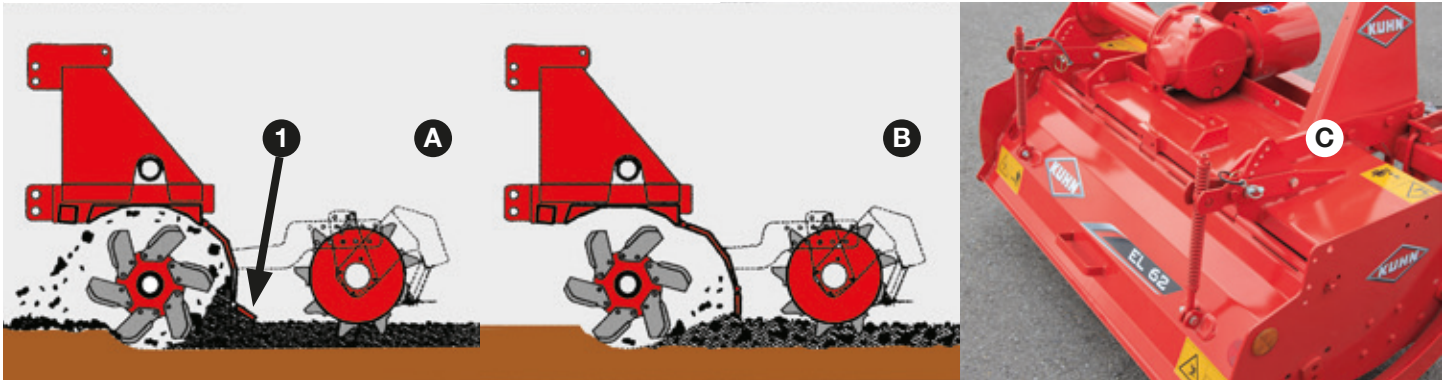

HOW MUCH CRUMBLING AND LEVELLING? YOUR CHOICE!

If the rear hood is positioned close to the rotor **A**, it accumulates soil until the latter is recycled to the front, which results in a high crumbling degree. In wet conditions or in plant residues, the machine will cope better with a more open rear hood **B**. Even more efficiency is provided with the levelling extension available on EL 62, 82 and 92 **1**. The rear hood is spring-loaded **C** for an optimal seedbed preparation where additional firming and levelling is needed.

SIMPLE AJUSTMENTS

Adjusting the rear hood is easy and efficient: by check chains on EL 43 and pins on EL 53 to 92. The levelling extensions of the bigger models are easily adjustable by pins.



THE KUHN PLUS: COMPACT DESIGN

All KUHN power tillers for vineyards and orchards are of very compact design for efficient operations in narrow rows. While the EL 43 is additionally known for its exceptionally low profile for passing safely under overhanging branches, it is the small overall to working width ratio of EL 62, 82 and 92, which is convincing. Moreover, the rounded hood edges and skids protect plants from being damaged.



COMPACT TOOL FOR GARDENS, GREENHOUSES AND LANDSCAPE

The EL 43 power tiller is a versatile tool and suitable for various tasks. It has been designed for seedbed preparation, gardening, greenhouse operations, but also landscape maintenance. It is particularly suited for compact and small tractors of 15 (11 kW) to 40 (30 kW) horsepower.



LANDSCAPE DESIGNS AND MORE

The compact design and low profile of the EL 43 power tiller allows the tiller to work safely under overhanging branches and close to greenhouses.



Source: Pirella/Rosemarie Doll

WORKING DEPTH CONTROL: MAKE YOUR CHOICE

All EL 43 power tillers are fitted as standard with easily adjustable depth control skids **1**. Where necessary optional depth control wheels are available **2**.

The latter are standard on EL 53 tillers. Optional skids **3** or heavy-duty wheels **4** with larger diameter and a more robust wheel column are available as option for the EL 53.

No restrictions from easy operations to more demanding applications!

FLEXIBILITY TO MEET ALL KINDS OF SOIL PREPARATION

Designed for operation in demanding environments on tractors with greater horsepower, the EL 53 meets the needs of contractors, landscapers, and farmers who demand the most from a tiller. Built considerably heavier than the EL 43, it is the ideal tool for the soil preparation needs of vineyards, orchards, landscape contractors, nurseries, market gardeners, and parks.

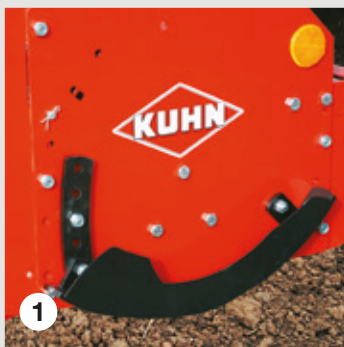

QUICK HITCH COMPATIBLE

With a simple optional adaptor the hitch of EL 53 (as well as EL 43) are compatible with the North American cat.1 Quick Hitch for faster attachment and removal.



TRULY MULTIPLE-PURPOSE TOOLS!

The EL 62, 82 and 92 KUHN power tillers are the result of very long experience in soil preparation and many years of research and development. Particular care has been given to following fundamental criteria:

- a design for demanding vineyard, market garden, horticulture and tree nursery professionals,
- a high level of versatility and adaptability,
- simple adjustments enabling fast adaptation to all situations,
- high reliability and long life for your peace of mind.



MULTIPLE HIGHLIGHTS

GREAT ROBUSTNESS

Rotor drive with case hardened forged steel gearwheels – frame made up of large box section casing.

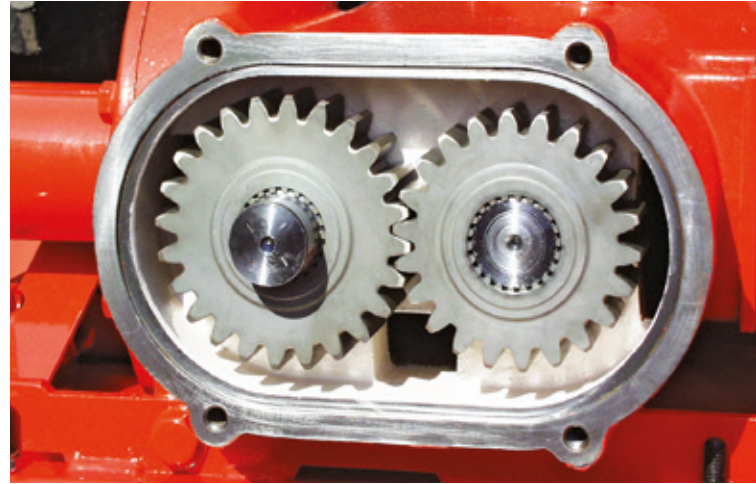

COMPACT DESIGN COMBINED WITH VERSATILITY

Slim overall to working width ratio – continuous lateral offset yokes on EL 62 – for vineyards, market gardens, horticulture, tree nurseries.

HIGH WORK QUALITY UNDER ALL CONDITIONS

Optimized design of rear hood – rear hood adjustable for adapting work intensity – C-blades for optimum tillage and plant residue handling.



EFFICIENCY - VERSATILITY - ADAPTABILITY



DEPTH CONTROL: MULTIPLE CHOICES

On all models, working depth is controlled and adjusted by means of skids **1** or wheels **2**. On machines with 1.80, 2.05 and 2.30 m working width, rollers are available as option: Crumbler roller **3** with large diameter of 390 mm (15") with removable bars, Packer roller **4** with diameter of 485 mm (19"), recommended for very wet conditions or clayey soils.



OPTIONAL EQUIPMENT: MULTIPLE POSSIBILITIES



SIDE SEPARATING DISCS:

avoid ridge formation between two passes and facilitate work in long plant residues, easily adjustable by a pin.



TRACK ERADICATORS:

loosen the soil behind tractor wheels, made up of four flexible tines adjustable in height and distance.



SIGNALLING EQUIPMENT:

replaces the tractor signalling when covered by the power tiller.



L-BLADES:

For shallow cultivation and reducing weeds, the rotor can be fitted with L-blades.



COUNTER-FLANGES:

EL 92 power tillers can be fitted with counter-flanges for reinforced blade hold in stony conditions.



SMALL TILLAGE SPECIALIST

KUHN “orchard-vineyard” power harrows: specialists through their dimensions, shape and equipment! No compromises have been made compared to models with larger working widths. A rear PTO is fitted as standard on all units to easily adapt secondary rear implements required for vineyard and orchard work.



WELL ADAPTED SHAPES

With their low height, rounded frame edges combined with narrow widths, the HRB 102 series is the ideal tool for specialized work.



COMPACT AND ROBUST HOUSING

The trough, rotor flanges and blade holders form a compact and robust assembly. The small distance between the trough and the top of the blade holders prevent stones from getting jammed. Moreover, the soil flow is directed down towards the blades.





DEPTH CONTROL

A large diameter Crumbler roller requiring no maintenance enables good ground hold and an efficient working depth adjustment.

The HRB 202 can also be equipped with a Packer roller (Ø 485 mm).

CENTRAL GEARBOX

This robust cast iron gearbox with rear PTO enables flawless rotor drive.

EASY TRANSPORT

With their small width, these machines are easily and safely transported from one field to another.

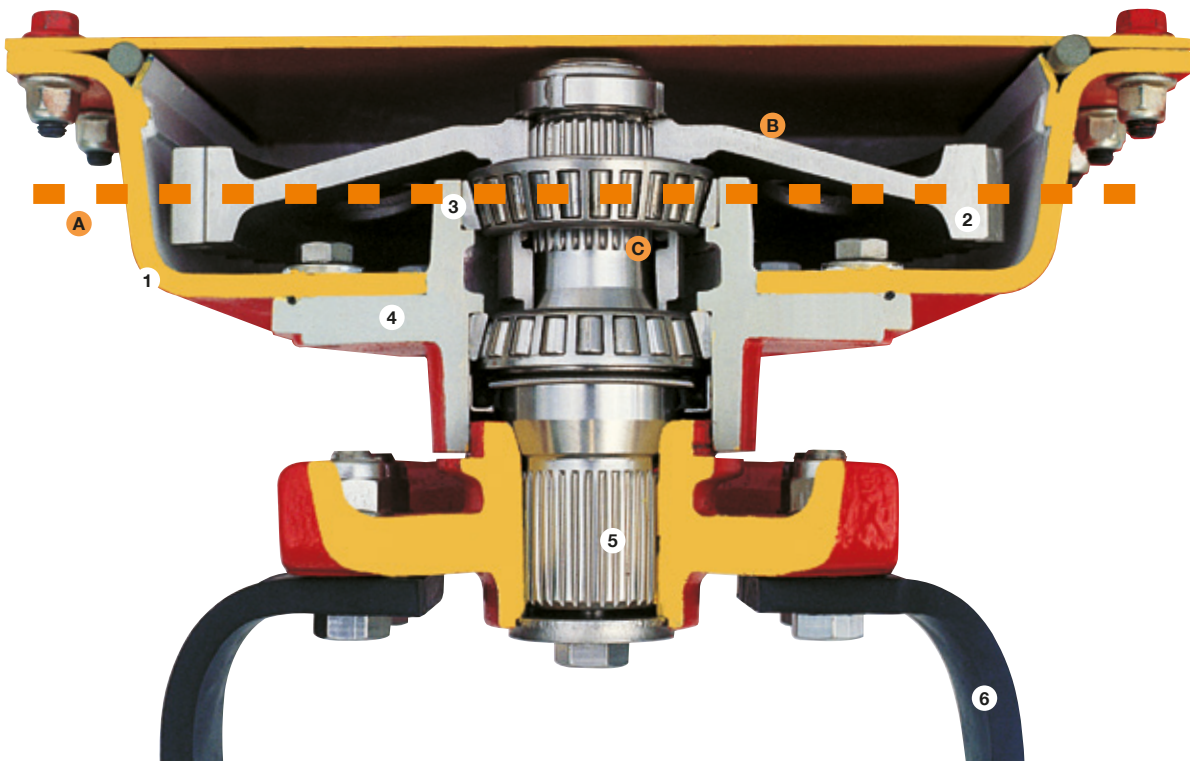

RELY ON ROBUSTNESS OF KUHN POWER HARROWS

- 1 MAINTENANCE-FREE HIGHLY RIGID TROUGH:** 6 mm thick on HRB 122-152-182 and 8 mm thick on HRB 202 - made from fine grain high tensile steel - contains semi-liquid grease for permanent lubrication of pinions and gearwheels - O-rings and lip joints ensure sealing for a longer service life.
- 2 NO GEARWHEEL OVERHANG:** convex treated and forged steel gearwheels so that the drive forces (A) - are transmitted at the centre of the upper roller bearing (over-dimensioned) without creating an overhang - high capacity shaft guidance and torque transmission capability thanks to the important spline length in contact with the shaft.
- 3 NO MAINTENANCE ON BEARINGS:** large dimension conical roller bearings - always perfectly aligned in a one-piece cast housing not subject to distortion - factory preloaded with a calibrated spacer (C), no further adjustments required.
- 4 PERFECT BEARING HOLD:** gear case protection ensured by thick cast iron housings (18 mm).
- 5 NO PLAY ON THE SPLINE LEVEL:** rotor shafts with rolled splines obtained by metal compression (no milling) - perfect connection with the shaft thanks to the conical centring of the blade holders (KUHN patent), preventing play on the spline level.
- 6 BLADES:** highly resistant to shocks and wear thanks to their large sections - heat treated 14 mm thick and 280 mm long.

		EL 43 105/130/150/190*	EL 53 100/130/155/190*	EL 62/62D 120/130/155/ 165/180/210*	EL 82 130/155/180/205	EL 92 180/205/230
Working width (m/ft)		1.07 - 1.27 - 1.48 - 1.89	0.97 - 1.27 - 1.52 - 1.88	1.20 - 1.28 - 1.53 - 1.65 - 1.78 - 2.10	1.30 - 1.55 - 1.80 - 2.05	1.80 - 2.05 - 2.30
Overall width (m/ft)	with skids	-		1.35 - 1.45 - 1.70 - 1.81 - 1.94 - 2.27	1.67 - 1.92 - 2.17 - 2.50	2.17 - 2.50 - 2.76
	with wheels	-		1.30 - 1.39 - 1.64 - 1.76 - 1.88 - 2.20	1.47 - 1.72 - 1.97 - 2.30	1.97 - 2.30 - 2.55
Minimum power requirement (kw/hp)		10/14 - 12/16 - 13/18 - 15/20	13/18 - 18/24 - 21/28 - 24/32	17/23 - 19/25 - 22/30 - 24/33 - 26/35 - 31/42	24/33 - 29/39 - 33/45 - 38/51	33/45 - 38/51 - 43/58
Maximum tractor engine power (kw/hp)		30/40	37/50	48/65	63/85	74/100
PTO speed (min ⁻¹)		540				
Drive safety system		friction slip clutch			shear bolt cut out clutch	
Rotor speed (min ⁻¹)	Single speed gearbox	211	244	224	-	-
	Duplex gearbox	-		206 - 245	212 (standard)	194/230 (standard)
Rotor diameter (mm/in)		390	430	450	525	
Number of mulch blades per flange/total		4/20 - 4/24 - 4/28 - 4/36	6/24 - 6/30 - 6/36 - 6/48	6/30 - 6/30 - 6/36 - 6/42 - 6/42 - 6/54	6/30 - 6/36 - 6/42 - 6/48	6/42 - 6/48 - 6/54
Min. and max. working depth (cm/in)		5 / 15		5 / 18	5 / 23	
Working depth control		skids (standard), wheels (option)	wheels (standard), skids or HD wheels (option)	skids or wheels	skids, wheels or rollers (from 1.80/5'11)	
Offset to the right (cm/in)		22 - 32 - 42 - fixed	15.5 - 30 - 30 - fixed	17 (120) - 20 (130 - 180) - fixed (210)	22 (130-180) - fixed (205)	11 (180) - fixed (205-230)
Attachment		cat. 1 / cat. 1 quick hitch	cat. 1 et 1 N / cat. 1 quick hitch	cat. 1N - 1 and 2		cat. 1 - 1 and 2
Weight (kg/lbs)	with skids	210 - 225 - 240 - 265	-	-	-	-
	with wheels	-	250 - 275 - 295 - 330	316 (62D-130) - 382 (62D-165) - 390 (62D-180) - 445 (62D-210)	-	-
	with skids and parking stands	-	-	282 - 295 - 330 - 360 - 365 - 420	-	-
	with skids or wheels	-	-	-	395 - 430 - 465 - 510	525 - 570 - 605
	with Crumbler roller	-	-	-	625 (205)	625 - 685 - 725
	with Packer roller	-	-	-	770 (205)	830 (180) - 895 (210)



KUHN PARTS

Designed and manufactured to rival time

KUHN foundries and forge as well as a high-level manufacturing process allow the production of spare parts to defy time. You can truly rely on our know-how and our genuine parts. Farmers benefit from our client support and logistics services via any KUHN PARTS warehouse, which provide quick and reliable repair solutions in cooperation with your nearest authorized KUHN dealer.



	HRB 122	HRB 152	HRB 182	HRB 202	HRB 202 S
Working width (m/ft)	1.20	1.50	1.80	2.10	2.10
Overall width (m/ft)	1.30	1.59	1.89	2.19	2.19
Minimum power requirement (kW/hp)	18/25	22/30	26/35	30/40	
Maximum tractor power (kW/hp)	59/80				
Rear PTO stub	◆				
PTO shaft safety	shear bolt cut out clutch as standard				
Working depth adjustable up to (cm/in)	20				
Blade attachment	bolted blades				FAST-FIT blades
Attachment	cat. 1N (narrow) 1 and 2 - adjustable lower link brackets			cat. 2 or 3 - pivoting lower links	
Depth control	Crumbler roller			Crumbler or Packer roller	
Crumbler roller ø 390 mm	◆				
Packer roller ø 485 mm	◇				
Weight (kg/Lbs)	with Crumbler roller	440	500	550	730
	with Packer roller	-			840

*Some machines and services are not available in all countries.

◆ standard ◇ option -- not available

KUHN SERVICES* Maximize the use and productivity of your KUHN equipment

*Not all services and equipment are available in every country.

KUHN sos order

EXPRESS SPARE PARTS SERVICE 24/7

You urgently need spare parts? With KUHN SOS order benefit from express delivery seven days a week, 365 days a year. Thus, you can minimize machine downtime considerably and increase your work output.

KUHN protect +

THE CHOICE OF PROFESSIONALS!

Benefit from 36 months in complete serenity because of KUHN's protect + warranty. You can concentrate exclusively on your work and the performance of your machine. Because this is what you expect, when investing in high-tech machinery.

KUHN i tech

FOR EVER QUICKER REPAIRS!

An unexpected technical problem always occurs at the wrong time. Your KUHN dealer can support you quickly and efficiently thanks to KUHN i tech. With this 24/7 online service, a quick and exact diagnosis is possible.

KUHN finance

INVEST RATIONALLY!

New machine necessary, financing unsure? Modernize your equipment and develop your farm with KUHN finance, in total safety and according to your needs and demands. We offer custom-made finance solutions, adapted to your requirements.

EL

HRB

COMPARE TO FIND THE EL OR HRB, WHICH EXACTLY FITS ON YOUR TRACTOR!

Working width (m)	Maximum tractor power (m)					
	29 / 40	37 / 50	48 / 65	59 / 80	63 / 85	74 / 100
1.00/1.05	EL 43/105	EL 53/100				
1.20			EL 62/120	HRB 122		
1.30	EL 43/130	EL 53/130	EL 62/130		EL 82/130	
1.50/1.55	EL 43/150	EL 53/155	EL 62/155	HRB 152	EL 82/155	
1.65			EL 62/165			
1.80			EL 62/180	HRB 182	EL 82/180	EL 92/180
1.90	EL 43/190	EL 53/190				
2.05			EL 62/205		EL 82/205	EL 92/205
2.10				HRB 202		
2.30						EL 92/230

KUHN provides many solutions to optimize your vineyards and orchards



1



2



3



4

1. Soil preparation tools 2. Fertiliser spreaders 3. Shredders 4. Shredders with collecting devices for energy recovery

For more information about your nearest KUHN dealer,
visit our website
www.kuhn.com

You Tube

Visit us on our YouTube channels.



www.kuhn.com

Your KUHN dealer

KUHN SAS

4 Impasse des Fabriques - BP 50060
F-67706 Saverne CEDEX - FRANCE

KUHN NORTH AMERICA, INC.

1501 West Seventh Avenue - Brodhead, WI 53520 - USA

KUHN FARM MACHINERY PTY. LTD

313-325 Foleys Road - Deer Park, VIC, 3023 - AUSTRALIA

KUHN FARM MACHINERY (U.K.) LTD

Stafford Park 7 - GB TELFORD/ SHROPS TF3 3BQ

Information given in this document is only for information purposes and is non-contractual. Our machines are in compliance with regulations in force in the country of delivery. In our literature, and for improved illustration of certain details, some safety devices may not be in operating position. When operating these machines, these devices must be in position in accordance with the requirements indicated in the operator's manuals and assembly manuals. Respect the tractor gross vehicle weight rating, its lift capacity and maximum load per axle and tyres. The tractor front axle load must always comply with the regulations of the country of delivery (In Europe, it must reach minimum 20 % of the tractor net weight). We reserve the right to change any designs, specifications or materials listed without further notice. Machines and equipment in this document can be covered by at least one patent and/or registered design. Trademarks cited in this document may be registered in one or several countries.

Also find KUHN on

